

Sennetech

SCT-1070

**CAMERA CONTROL CODE TRANSLATOR
PANASONIC RS-485 to BOSCH BIPHASE Ver. 1.2**

www.sennetech.net

Sennetech, Inc. 6455 W. Bath Rd. Perry, MI 48872 U.S.A. Ph (517) 675-1150 Fax (517) 675-1151

PRODUCT DESCRIPTION

The SCT-1070 is a Panasonic to Bosch camera control code translator designed to permit control of Bosch cameras from Panasonic controllers. It receives Panasonic RS-485 commands and transmits the appropriate commands in Bosch biphasic code format. There are four independent biphasic outputs.

Input Panasonic baud rates of 2400, 4800, 9600, or 19200 are automatically detected.

The unit can be configured with internal switches to send only fixed speed biphasic code for compatibility with older Burle receivers.

Panasonic camera addresses can be offset in blocks of 8 to send higher Bosch addresses than are available from a Panasonic control system.

Input and output connections are made with mating screw terminal connectors. Front panel LEDs indicate power, receive, transmit, and status.

There is an optional 19" rack mount panel (one rack unit high).

SPECIFICATIONS

SIZE:	19"W x 1.75H x 5.45D
WEIGHT:	1.5 lbs.
POWER:	9Volt to 18Volt AC or DC at .75 Watts
INDICATORS:	Front panel LEDs: Power, Rx, Tx, and Status
PANASONIC INPUT:	(1) 3-pin mating screw terminal connector
PANASONIC RESPONSE:	(1) 3-pin mating screw terminal connector
BIPHASE OUTPUTS:	(4) 3-pin mating screw terminal connectors

To install the case on the rack mount frame, remove the front panel and the plastic bezel. The rack mount frame takes the place of the bezel as shown below.

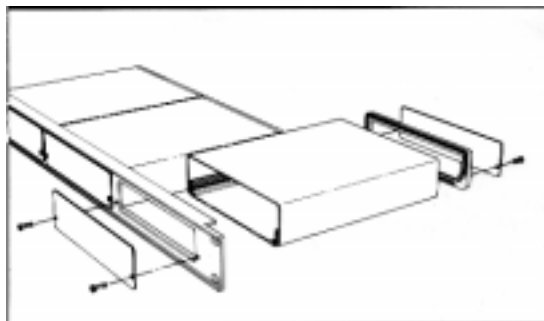

SETTING THE SWITCHES

To set the configuration switches, remove the back panel, which is secured by two screws. Then slide the cover back to expose the switches. The switches can be changed while the code translator is powered up and the new settings will take effect immediately.

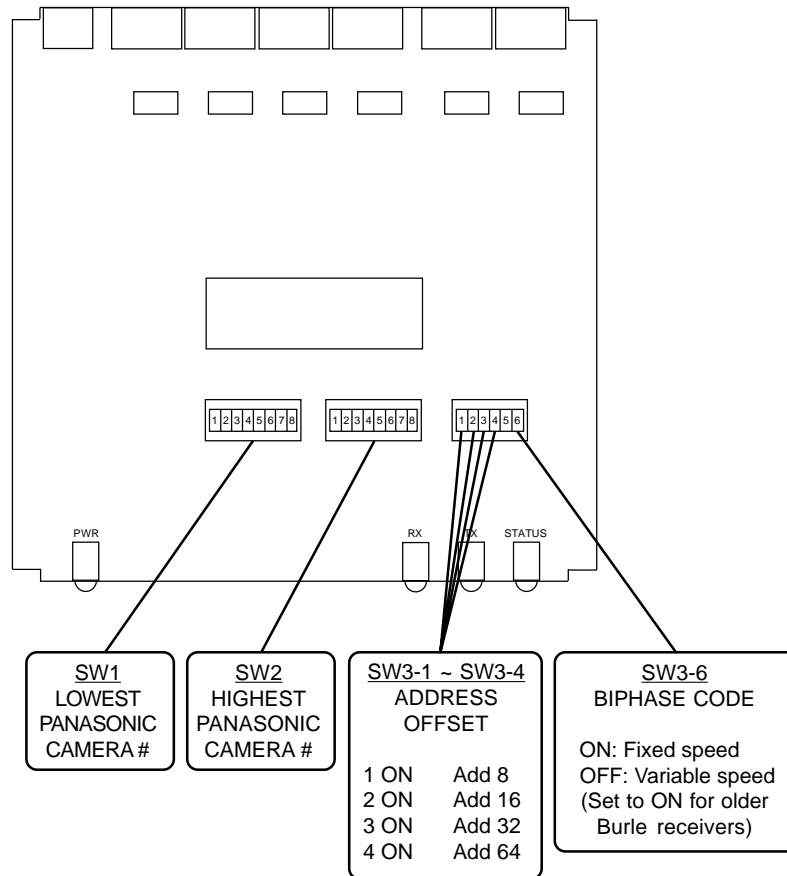

The code translator responds to Panasonic communications as a range of Panasonic cameras. To avoid interference on the response line, set the lowest and highest camera switches to include the Bosch cameras and exclude any Panasonic cameras on the same RS-485 data line.

If the control system is set up for oneway mode, the response line can be left disconnected and the switches can be set to include all cameras.

Some Panasonic matrix systems will only send packets addressed to cameras 1 ~ 8 from each data card. The address offset switches add a number to the Panasonic camera address to get higher Bosch camera addresses. The offset switches are cumulative; if switches 1 and 3 are on, 8 + 32 for a total of 40 will be added to the current Panasonic address. Thus, a Panasonic packet addressed to camera #1 will be sent to Bosch camera #41. The switches determining the lowest and highest camera addresses still apply only to the Panasonic camera numbers.

INSTALLATION

FRONT PANEL

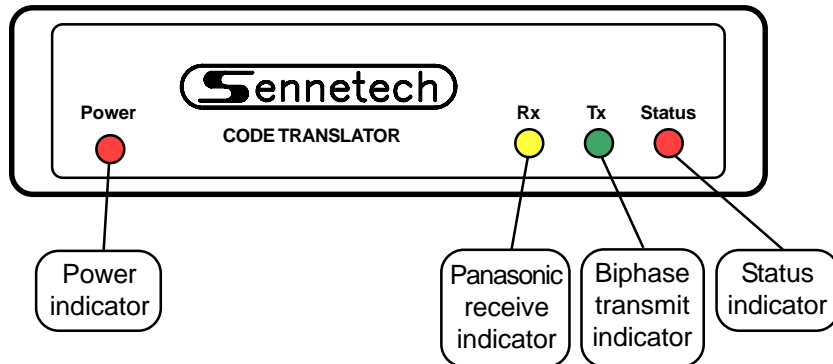

REAR PANEL

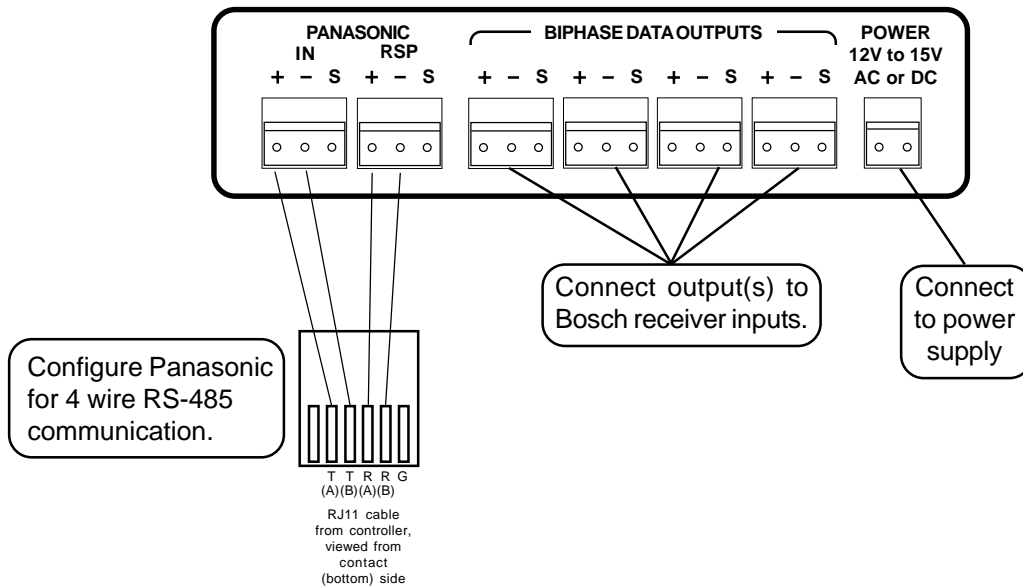

The Rx LED will light when there is any data on the input lines.

The code translator will automatically detect the input baud rate from 2400 baud to 19200 baud.

The Status LED will flash if the input data is not recognized, i.e. if the wires are reversed or the data is not valid camera control code. It will flash momentarily during the auto-detect process.

The Tx LED flashes when biphase output is being sent. The Pan, Tilt, Zoom, Focus, and Iris commands are sent repeatedly. Other commands, such as presets, are only sent once.

Connection with WJ-SX550 or WJ-SX850 Matrix Systems

The WJ-SX550 matrix requires the WV-PB5548 data board and the WJ-SX850 matrix requires the WJ-PB85R08 data card to supply RS-485 control code to the code translator. Each card handles data for up to eight cameras, so a code translator is required for each card.

The cards must be configured through the Panasonic setup software for daisy chain operation. The code translator will auto-detect the baud rate from 2400 baud to 19200 baud. If the installer is free to choose the baud rate, 9600 N81 is recommended.

In daisy chain mode, the data for all eight cameras will be sent only from the top output set of connectors on each card. The data packets from each card will be addressed to cameras 1~8. Use the code translator offset switches if the addresses need to be changed to match the Bosch camera address settings. For example, on the code translator connected to the second data card for cameras 9~16, set the switches to add 8 to the input address.

Remember, the offset switches are cumulative, so, for example, turning on the switches adding 8 (SW3-1) and 16 (SW3-2) will result in an address offset of 24.

The switches on the data cards should be set for 4 wire mode. The WJ-PB85R08 card has additional switches for setting handshake mode and the number of retries. The recommended setting is no handshake mode with no retries. Then the response lines from the code translator can be ignored.

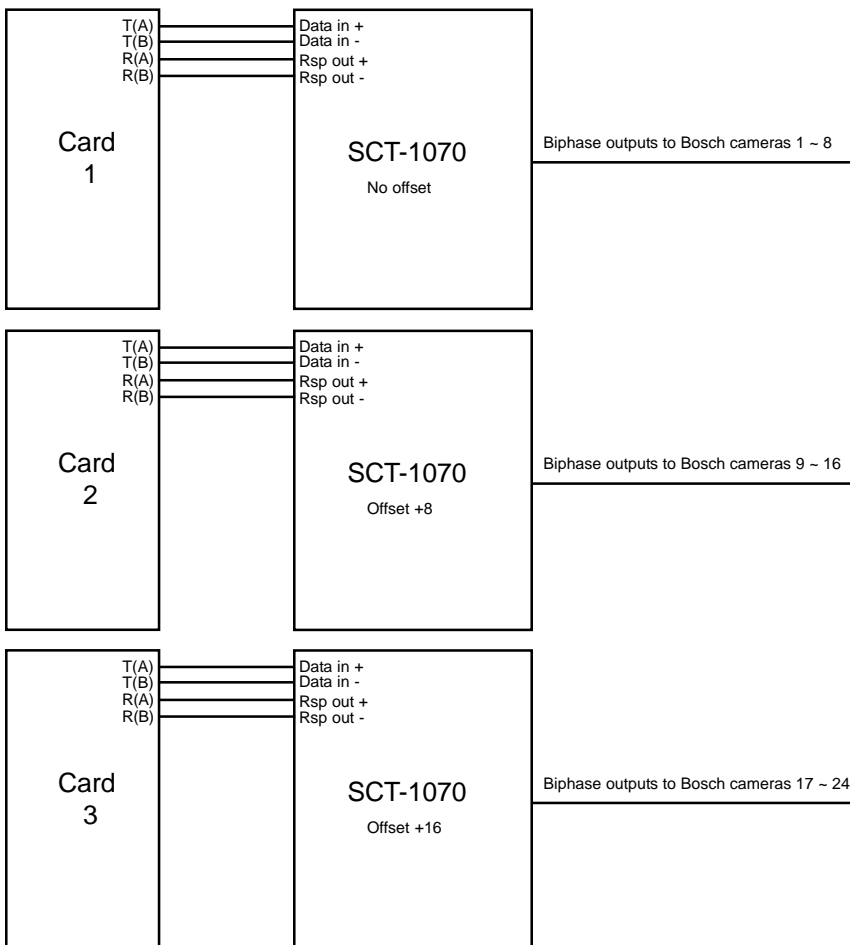

OPERATION

PTZ

The code translator converts Pan, Tilt, Zoom, Focus and Iris commands directly.

Presets

Panasonic presets from 1–60 are converted to Bosch presets.

Other commands are converted according to the following table.

<u>Panasonic Command</u>	<u>Bosch Command</u>	<u>Autodome Function</u>
Autopan	On 2	Autopan between limits
Patrol Play	On 50	Continuous pattern playback
Patrol Learn	On 100	Start pattern record
Patrol Stop	Off 100	End pattern record
Program Preset 61	Set 101	Set autopan left limit
Program Preset 62	Set 102	Set autopan right limit
Preset 64	On 997	Momentarily display camera address
Program Preset 64	Off 90	Unlock Dome (so the menu can be accessed)
Cam Setup Menu On	On 46	Display camera setup menu

